

Fire Hydrant/Hosereel Portable Tester

INSTRUCTION MANUAL

INTRODUCTION

The AMBIT P.F. Series of portable testing units have been primarily designed to meet the need for accurate pressure and flow measurement at the service point of fire hydrants and/or hose reels. Custom built variations of these basic units can be supplied to satisfy many other similar applications in a variety of industries where pressure/flow relationships need to be established.

THE EQUIPMENT

Consists of a portable Aluminium cabinet into which is fitted a flow indicator, a pressure gauge and a flow tube/s.

Both instruments are fitted into a detachable front 'loading' panel which enables easy access for service or maintenance work.

The flow instrument incorporates high performance microprocessor electronics with the convenience of full-time battery operation and will withstand the day to day rugged handling normally required of a portable instrument. The standard flow ranges are :-

3/4" Tube : 0/180 LPM (or optional LPS)

2 1/2" Tube : 0/1800 LPM (or optional LPS)

The accuracy for the flow instruments are :-

3/4" Tube : $\pm 2\%$ F.S.D. up to 120 LPM & $\pm 3\%$ from 120 to 180 LPM (or optional LPS)

2 1/2" Tube : $\pm 2\%$ F.S.D. up to 1200 LPM & $\pm 3\%$ from 1200 to 1800 LPM (or optional LPS)

The pressure gauge is of a heavy duty construction and has an accuracy of $\pm 1\%$ of full range. The standard pressure gauge has a range of 0/1600 kPa and is fitted with a "Vibrageauge" movement to help dampen out pressure fluctuations.

All screws are stainless steel and wetted parts are either stainless steel or polypropylene.

The unit is guaranteed for a period of 12 calendar months from the date of supply, with the exception of the paddle wheel flow sensor, which is susceptible to damage from debris in the line.

CONDUCTING A TYPICAL TEST

1. CAUTION

Prior to connecting the test box to any Hydrant/Hosereel outlet it is most important that the service outlet valve be fully opened for not less than 2 minutes. This should flush the pipeline clear of any foreign particles that could possibly damage the flow sensor (See TROUBLESHOOTING – page 4).

Please ensure the Hydrant/Hosereel Tester is securely held down, prior to allowing flow through the unit.

Where ever possible, it is highly recommended a diffuser be fitted to the outlet. When opening the valve (if fitted), please ensure valve is opened SLOWLY

2. IMPORTANT

To obtain specified accuracy of the Flow indicator:-

(a) **DO NOT** Fit valves other than 'full bore' ball valves to either the inlet or outlet connections of the tester.

(b) **DO NOT** Introduce any partial obstruction or bend within 250mm of either connection.

3. CONNECTING THE TESTER

Connect the tester to the service outlet via a fire hose to the inlet connection. The tester is now ready for use.

4. STATIC & RESIDUAL (DYNAMIC) PRESSURE TEST

For Static Pressure Test

If fitted (as optional extra) CLOSE the outlet valve on the tester. If valve is not fitted, cap the outlet with a blanking cap.

For Residual (Dynamic) Pressure Test

A diffuser should be fitted to the valve & then the valve partially opened.

5. Open the service outlet valve and the 'static' (no flow) pressure will be indicated on the pressure gauge.

6. FULL (UNRESTRICTED) FLOW TEST

Continue on from step 4 (above) and open the test box outlet valve. The flow meter will now

Indicate the available flow in L.P.M. (or LPS if supplied). During this test the pressure gauge will indicate zero or just above zero.

7. FULL RESTRICTED FLOW TEST

After selecting and fitting the appropriate hose reel nozzle repeat the test as in step 5 (above). The flow meter will once again indicate the available flow rate via this nozzle and the pressure gauge will indicate at what pressure.

8. OPERATION OF DIGITAL DISPLAY TOTALIZER (type 8150)

The 8150-1 display shows the flow rate in large numerals and a totalizer value in smaller numerals. Any one of three different totalizers can be selected as the standard display.

Press the UP or DOWN keys to scroll through all three totalizer values during normal operation.

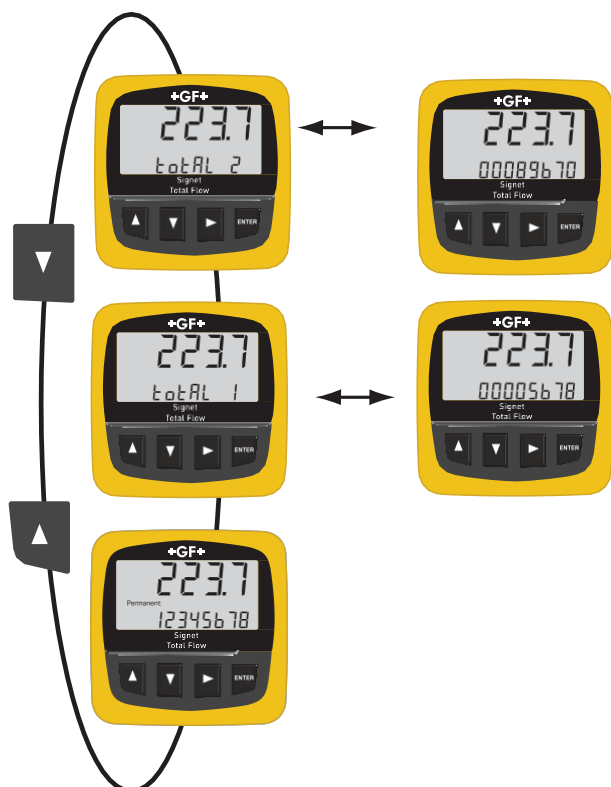

RESETTING OF DIGITAL DISPLAY TOTALIZER (type 8150)

- (i) Press UP key to scroll to "total 1" display.
- (ii) Press and hold the RIGHT arrow key until the display shows "rst tot1".
The totalizer will flash for 8 seconds and then it will automatically reset to 00000000.
- Press the ENTER key while the display is flashing to reset immediately.
- While the total value is flashing, you can cancel the reset by pressing UP and DOWN keys together.
- Totalizer #1 will be displayed for 5 minutes after the reset, then the standard totalizer selection will return.
- Press the UP or DOWN key to scroll back to the standard display immediately.



10. NO FLOW AND ELAPSED TIME DISPLAY

If the flow stops, the Flow Rate displays the number of hours since flow was last detected. This display will alternate with the normal Totalized Value and standard "no FLo" display every five seconds. Any movement of the rotor in the pipe will reset the ELAPSED TIME display.

Illustrated: No flow for 3 hours



TROUBLE SHOOTING AND MAINTENANCE

PART A. THE FLOW SYSTEM

A1. DIGITAL FLOW INDICATOR

(i) NIL DISPLAY

Check :- Batteries are installed correctly.

That lead wires from the Flowsensor are appropriately fastened to the correct terminals.

(ii) INDICATOR ERROR

Check :- Flowsensor operation, (See 'Flowsensor' below).

NOTES

1. The digital flow indicator is individually factory calibrated & issued with a "K" factor to match the unit. The "K" factor is programmed into the flow indicator during manufacture and is shown on a label on the side of the indicator.
2. Page 5 & 6 of this manual show details on correct wiring & battery installation.
3. Page 2 & 3 of this manual provides information on the normal operating display & also how to reset the resettable total (if desired).

A2. THE FLOWSENSOR

The operation of the flowsensor is dependant on correct installation in the installation fitting. The flowsensor has two lugs inside the cap which locate in the slots in the flowsensor insert. The insert slots must be parallel with the liquid flow. Care must be taken that the flowsensor is not over-tightened in the insert, as this may cause the insert to rotate, leaving the paddlewheel misaligned to the flow direction.

Debris in the flow may foul or damage the paddlewheel, which would then require removal and replacement.

To remove the paddlewheel from its housing rotate the 'red' locking cap anti-clockwise until the cap is clear of the housing insert, then using the wire bale, remove the complete paddlewheel assembly from its housing by 'gently' twisting and pulling outwards.

A3. PADDLEWHEEL REPLACEMENT

- (i)** With a small flat-bladed screwdriver, gently pry away one of the paddlewheel mounting lugs from the pin.
- (ii)** When one end of the pin is free gently work the paddlewheel and pin out of the remaining lug.
- (iii)** Clean or replace.
- (iv)** To reinstall the paddlewheel and pin reverse steps (i) and (ii) above.
- (v)** The paddlewheel should spin freely when flicked by the finger.

The flowsensor 'O-Rings' should be checked periodically and replaced when necessary. The flowsensor shaft, 'O-Rings' and insert barrel need lubrication as required. Lubricate with silicone oil.

PART B. THE PRESSURE SYSTEM

B1. PRESSURE GAUGE

The pressure gauge is of a heavy duty construction and designed to withstand both normal transit and portable handling conditions.

Two common developments that can often indicate a faulty gauge are :-

- (i) The indicating pointer being off zero.
- (ii) A jerky pointer action when increasing or decreasing pressure.

In either condition the gauge should be removed and undergo an overhaul/calibration check.

B2. PRESSURE TUBE

In the event that the flexible pressure tubing between the flow tube and the pressure gauges becomes blocked, then remove the entire tube and pressure purge out and refit or replace with new tubing.

PART C. WIRING

- (i) Only one wire should be inserted into a terminal. Splice double wires outside the terminal.
- (ii) **External Reset for Total #1:** Use no more than 30m (100ft) of 2-conductor twisted-pair cable connected to a dry contact (for example, an ordinary door-bell button or relay contact).
- (iii) Only Totalizer #1 can be reset by the external connection.
- (iv) Total #1 will not be displayed unless it is the standard totalizer selection

INSTRUCTIONS

- (i) Remove 10mm (3/8 in.) of insulation from sensor cable conductors. 10mm
- (ii) Press down on orange lever to open terminal.
- (iii) Insert wire into terminal until it hits bottom.
- (iv) Release the lever to secure wire.



Use this wiring scheme for flow sensor model: 515 and 525

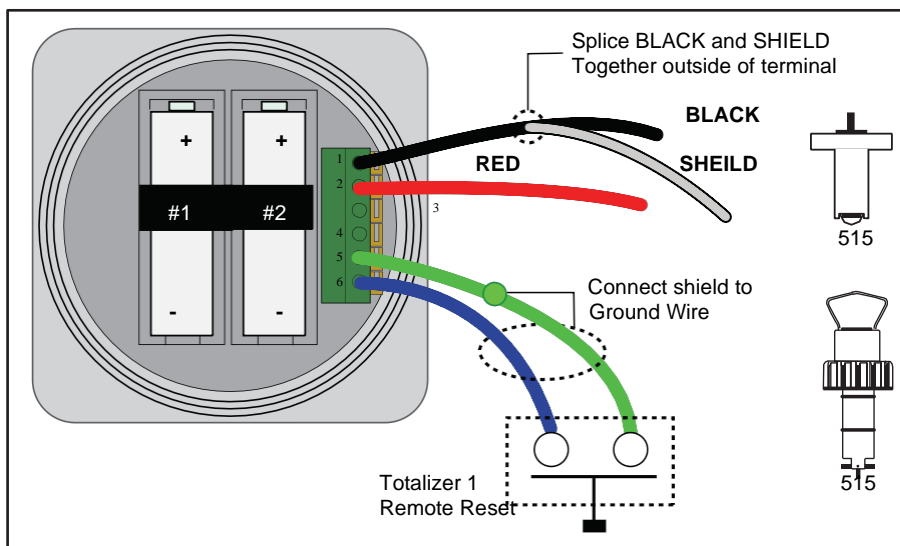

Terminal no.	Function
1 (top) Black	Signal Ground
2 Red	Sensor signal
3	Open Collector Signal
4	DC Power to sensor
5	Ground
6 (bottom)	Ext. Reset

PART D. BATTERY INSTALLATION AND REPLACEMENT

Two 3.6V Lithium thionyl Chloride batteries, AA-size (7400-0011) are included with the Totalizer.

NOTE: THE 8150 WILL NOT OPERATE WITH STANDARD 1.5V ALKALINE BATTERIES. USE 3.6 V LITHIUM BATTERIES ONLY!

- **Observe Polarity!** Note that both batteries should face the same direction.
- When the 'low battery' indicator appears on the display, **both** batteries should be replaced within 90 days.
- Remove and replace battery #1 first, then remove and replace battery #2. This ensures that all settings and totalizer values are saved.
- If the low battery symbol reappears for more than 10 seconds after installing new batteries, one battery is reversed, or battery #2 was installed before battery #1.
- Secure the batteries by fastening the hook-and-loop straps.

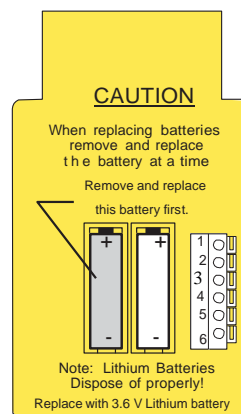

 **DISPOSE OF EXPENDED BATTERIES PROPERLY!**
Lithium batteries contain hazardous chemicals.
Dispose of batteries according to local regulation.