

## Magnetic Rotor Level Indicator

For working pressures up to 1000kPa

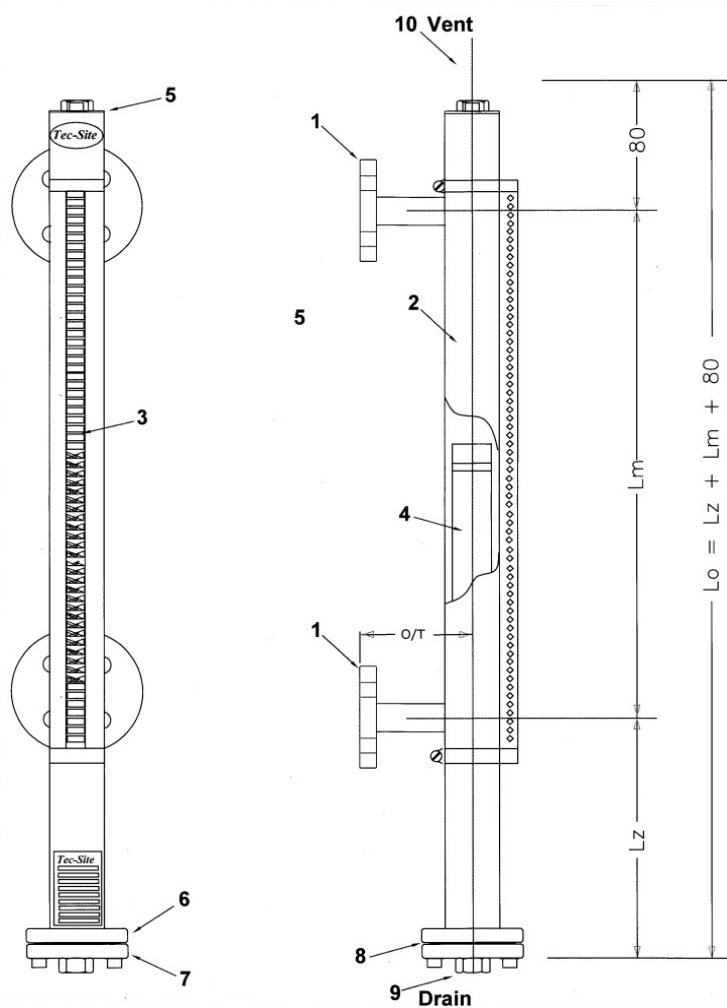

1. Process Connections : Flanged, 316L St St
  2. Float Chamber : 316L StSt, 38mm O.D. x 1.6mm wall
  3. Indication Rail : Polycarbonate/Aluminium, colours red/white (standard)
  4. Float : Polypropylene
  5. End Cap : 316L St St, tapped 1/2"NPT
  6. Float tube Flange : 316L St St
  7. End Flange : 316L St St, tapped 1/2"NPT
  8. Gasket : Buna N
  9. Drain : 316SS, 1/2"NPT (plugged)
  10. Vent : 316SS, 1/2"NPT (plugged)
- Lz Lengths : SG 0.8 : 290mm, SG 1.0 : 230mm, SG 1.2 : 175mm  
 O/T : 1/2" & 3/4"=100mm, 1" =115mm

Pressure Rating : 1000 kPa, hydro tested (cert included) to 1250 kPa.

Temperature rating : 100 Deg C

**Sales of ALL products are subject to our General Conditions of Quotation & Supply.  
 Technical specifications are subject to change without prior notice.**



## **AMBIT INSTRUMENTS PTY LTD**

ACN No 50 005 613 641

42 TITAN DRIVE CARRUM DOWNS 3201 VICTORIA AUSTRALIA.

Phone: 03.9776.8888 Fax: 03 9776.8656

Email: [contact@ambitinst.com.au](mailto:contact@ambitinst.com.au)

[www.ambitinst.com.au](http://www.ambitinst.com.au)

NATA ENDORSED CALIBRATION  
CERTIFICATES AVAILABLE



WORLD RECOGNISED  
ACCREDITATION

LAB No 3103