

Magnetic Rotor Level Indicator

For working pressures up to 1600kPa

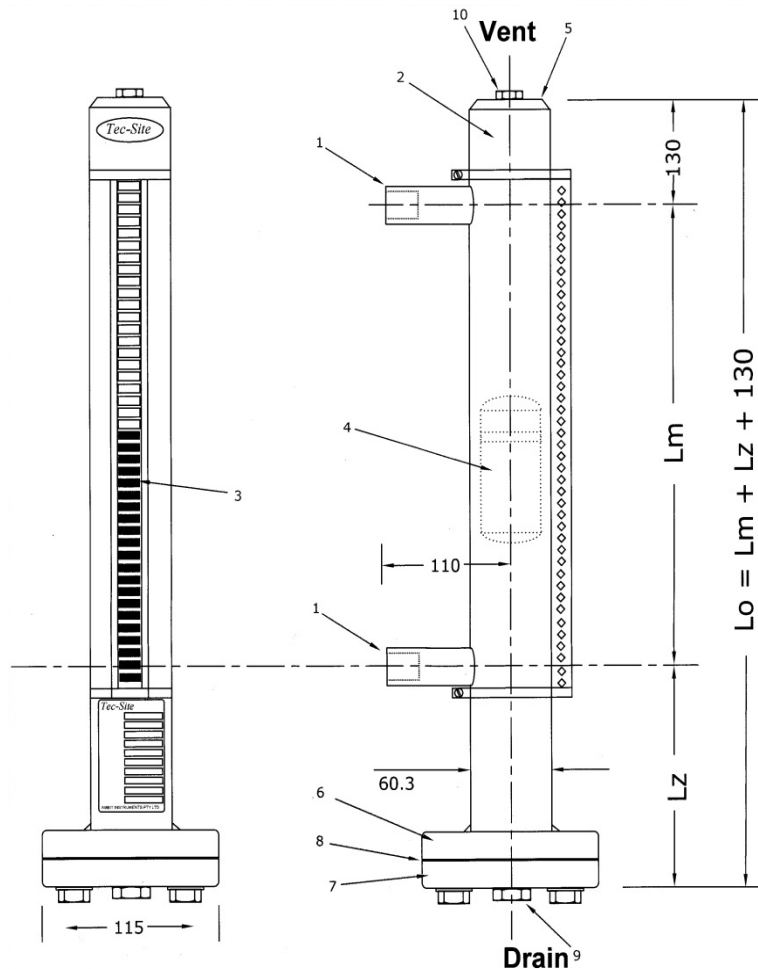

1. Process Connections : Threaded female, 316SS, 1/2" to 2"
 2. Float Chamber : 316L StSt, 50mm Sched 10, welded seam
 3. Indication Rail : Polycarbonate/Aluminium, colours red/white (standard)
 4. Float : 316SS, Titanium for Low Density
 5. End Cap : 316L St St, tapped 1/2"NPT
 6. Float tube Flange : 316L St St
 7. End Flange : 316L St St, tapped 1/2"NPT
 8. Gasket : Tensit BA Unit, options include PTFE, Spiral wound
 9. Drain : 316SS 1/2"NPT (plugged)
 10. Vent : 316SS 1/2"NPT (plugged)
- Lz Lengths for Standard Floats (S.G.)

0.66 to 0.74 : 345mm	0.72 to 0.83 : 290mm
0.83 to 0.94 : 240mm	0.92 to 1.07 : 205mm

Pressure Rating : 1600 kPa, hydro tested (cert included) to 2000 kPa.
 Temperature rating : 100 Deg C as standard with options up to 300 Deg C.

**Sales of ALL products are subject to our General Conditions of Quotation & Supply.
 Technical specifications are subject to change without prior notice.**