

# 800 Series

## STANDARD TEST GAUGE

The Ambit Series 800 Test Gauges are designed and built in our Melbourne factory to high quality standards. The maximum error of these gauges is guaranteed not to exceed +/-0.25% of the total range at any point on the scale.

The gauge incorporates an anti-parallax mirror scale to reduce reader error and a robust stainless steel case with highly polished bezel.

*Each gauge comes with a NATA endorsed test certificate.*

### Accuracy

+/-0.25% F.S. Fully complies with AS1349 4.1.1.

### Case/Bezel

304 Stainless steel

### Mounting

Direct Bottom - Model 800

### Window

Sheet glass

### Dial

Aluminium, mirror backed, black on white.

### Pointer

Knife edged adjustable & balanced, black finish.

### Bourdon tube

Beryllium copper

### Movement

Brass

### Socket (connection)

Brass, 1/2"BSPP

### Dial size (mm)

160

### Carry case

Upon request

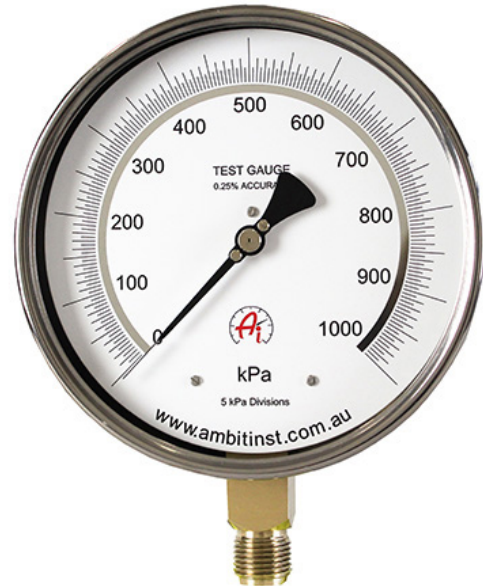

MODEL 800

### Standard Dial Layouts & Order Codes

Range kPa	Minor Divisions kPa	Range Code	Range kPa	Minor Divisions kPa	Range Code
-100/0	0.5	16	0/2500	20	78
0/60	0.5	67	0/4000	20	79
0/100	0.5	69	0/6000	50	80
0/160	1.0	70	0/10,000	50	81
0/250	2.0	72	0/16,000	100	82
0/400	2.0	73	0/25,000	200	84
0/600	5.0	74	0/40,000	200	86
0/800	5.0	98	0/60,000	500	87
0/1000	5.0	75	0/100,000	500	88
0/1600	10.0	76			

NON-STANDARD SCALES AND OTHER UNIT DESIGNATIONS ARE AVAILABLE ON REQUEST

To simplify ordering, order Model No. and range code only e.g.:-

(a) Direct Bottom - 800-76 (for range 0/1600kPa)

### Dimensions

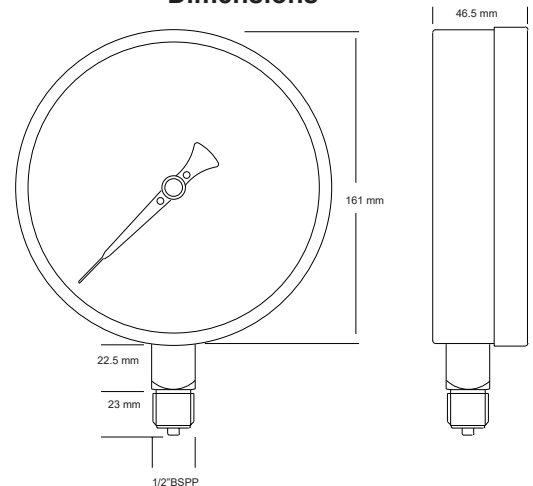

**Note:** It is necessary that we be advised if gauges are to be used on air or liquid when ranges are 1600kPa or less. This is due to the possibility of errors being introduced by liquid entering the bourdon assembly if the gauge has been factory calibrated for use on air.

Sales of ALL products are subject to our General Conditions of Quotation & Supply.  
Technical specifications are subject to change without prior notice.

**AMBIT**  
**INSTRUMENTS PTY LTD**  
ABN 50 005 613 641

Office & Factory | 42 Titan Drive, Carrum Downs, Victoria, 3201, Australia  
Ph: 03 9776 8888 | E: [contact@ambitinst.com.au](mailto:contact@ambitinst.com.au) | W: [ambitinst.com.au](http://ambitinst.com.au)