

# Flow meters, Flow switches and Flow transmitters

## A Small Vane-Style For Corrosive Fluids

 CSA Certified NRTL/C

 CE Marked (as noted)

NIST Traceable Calibration  
Certificate Available



SX shown with "A"  
style control box.

### DESCRIPTION

These variable-area flow meters have a spring-loaded swinging vane. Mounting is in-line and in any position. Straight pipe runs before or after the meter are not required. The all-mechanical sensing system directly drives the pointer and remote signaling devices.

### CALIBRATION

All flow meters are individually calibrated for fluids with the viscosity you specify (up to 3000 SSU (650 Centistokes). We compensate for your fluid's specific gravity. For NIST Traceability please consult factory.

### OUTPUTS

The flowmeter has outputs both visual and electronic. Visual displays are either pointer (with inscribed scale) or numeric. Signal outputs can be mechanical switch closure, 4-20 mA analog or both

(for signal redundancy). The switches can be general purpose or rated for hazardous locations (all classes, groups and divisions). The 4-20 mA transmitters are Intrinsically Safe if used with approved barriers.

### CONSTRUCTION MATERIALS

These flowmeters have plastic bodies, a wide variety of metal internals, and fittings. They are ideally suited to monitor flows of such fluids as corrosive liquids, seawater, deionized water, acids, caustics, and plating solutions. See selections in the "How to Order" section.

### LINE CONNECTION

Threaded units have a 7/8-14 inch SAE ports. Adapters are used to offer NPT port connections both male and female and in plastic or 316 SS (see "How to order" section). One inch diameter Van Stone flanges are offered in PVC.

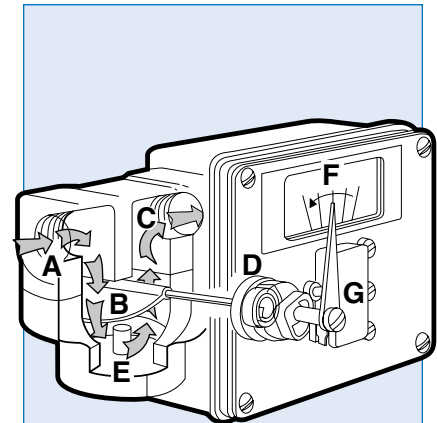

Fluid enters at **A**, passes around the semi-circular vane **B**, exits at outlet **C**. The vane resists the flow because of the spring **D**. The further the vane is pushed the larger the passageway **E** becomes. This minimizes the increase in pressure drop. The vane shaft turns to operate the pointer **F** and remote signal devices such as the switch **G**.

**HOW TO ORDER** Select appropriate symbols and build a model code number, as in example shown:

**EXAMPLE:** SX - P I F 6 GM-8R 4FS - 32V1.0 -

SERIES	
Small vane style corrosion resistant =	<b>SX</b>

HOUSING MATERIAL	
PVC =	<b>V</b>
Polysulfone =	<b>P</b>
Tefzel =	<b>T</b>

INTERNAL MOVING PARTS	
316 Stainless Steel =	<b>I</b>
Titanium =	<b>T</b>
Monel =	<b>L</b>
Hastelloy C =	<b>C</b>

SEAL MATERIAL	
Buna N =	<b>B</b>
EPR =	<b>E</b>
Viton® =	<b>F</b>
Kalrez™ =	<b>J</b>
Kalrez (dymanic)/Buna N (static) =	<b>A</b>
Kalrez (dymanic)/EPR (static) =	<b>H</b>
Kalrez (dynamic)/Viton (static) =	<b>K</b>

More are available if you consult with the factory.

Consult factory for compatibility of construction materials with the fluid involved.

MAX FLOW RATE LIQUIDS	
GPM	3, 4, 5, <b>6</b> , 7, 8, 9, 10, 15 & 20
LPM	10, 15, 20, 25, 30, 35, 40, 45, 50, 60, 75
CMH	.75, 1, 1.25, 1.5, 2, 2.5, 3, 3.5, 4, 4.5

SCALE CALIBRATIONS	
Calibrated in gallons per minute =	<b>GM</b>
Calibrated in liters per minute =	<b>LM</b>
Calibrated in cubic meters per hour =	<b>CMH</b>

Note: For specific calibrated increments and other scales consult factory

PORTING						
PORT ADAPTER						
	NPT	Max Flow	Plastic*	Plastic*	316 S.S.	
Inches	MM	(gpm)	Male	Female	Female	
1/4	6.350	8	<b>2MP</b>	<b>2FP</b>	-	
1/2	12.70	10	<b>4MP</b>	<b>4FP</b>	<b>4FS</b>	
3/4	19.05	10	<b>6MP</b>	<b>6FP</b>	<b>6FS</b>	
1	25.40	20	<b>8MP</b>	-	-	

\*Material will be same as housing

VAN STONE PIPE FLANGE		
Inches	Flanged Max Flow	Plastic (PVC only)
1/2	10	<b>4R</b>
1	20	<b>8R</b>

FLUID CHARACTERISTICS
Viscosity number followed by a 'V' (for SSU), 'C' (for centipoise), or 'CS' (for centistokes) followed by the specific gravity. Example: <b>32V1.0</b> would indicate a fluid with a viscosity of 32 SSU with a specific gravity of 1.0 (water). For dual viscosities (where there is a start up viscosity or where there may be a range) put in both values with a slash. Example: 32Ø/15ØV.9.

**A1 W R - C - 2D**

SERVICE		
Oil and dust tight (Type 12)	=	<b>N</b>
Weatherproof (Type 4)	=	<b>W</b>
Weatherproof, corrosion proof (Type 4X)	=	<b>X</b>

FLOW DIRECTION		
Left to right	=	<b>R</b>
Right to left	=	<b>L</b>
Up	=	<b>U</b>
Down	=	<b>D</b>

SPECIAL OPTIONS		
Stainless steel ID tag for customer supplied information	=	<b>ST</b>
High accuracy (+/-3%)	=	<b>HA</b>
Pin connector (See explanation for special options.)	=	<b>PC</b>
CSA enclosure / PVC window	=	<b>C</b>
Tempered glass window	=	<b>TG</b>
Clearance vane for ≥ 5 GPM	=	<b>Z86</b>
Wall mounting bracket	=	<b>W</b>
Foot mounting bracket	=	<b>F</b>

**SWITCH SETTING**  
 No symbol = Lowest possible setting (usually 10% of maximum flow)  
 Desired set point is assumed to be in flow units already selected (GPM). Give flow rate **2D** followed by a "D" for flow going down (flow failure) or a "U" for flow going up.  
 Example, 2D indicates a setting of 2 GPM in declining flow.

**CONTROL BOX & READOUT**

Basic Features ↓	Additional Options ↓	Standard resolution pointer and inscribed scale			High resolution pointer and inscribed scale	Separate junction boxes (with terminal strips) for switch & transmitter
		"A", "L" and "Z" Box			"R" Box	"T" Box
		Polysulfone	Aluminum	Materials of Construction 316 Stainless	Aluminum	Aluminum
These options all include inscribed scale and pointer plus one of the standard (non hazardous location) switches selected to the right.	No switch	<b>A0</b>	<b>L0</b>	<b>Z0</b>	<b>R0</b>	
	One SPDT (3 wire), CE	<b>A1</b>	<b>L1</b>	<b>Z1</b>	<b>R1</b>	
	One high vibration SPDT (3 wire), CE	<b>A1B</b>	<b>L1B</b>	<b>Z1B</b>	<b>R1B</b>	
	Two SPDT (3 wire), CE	<b>A2</b>	<b>L2</b>	<b>Z2</b>	<b>R2</b>	
	Two high vibration SPDT (3 wire), CE	<b>A2B</b>	<b>L2B</b>	<b>Z2B</b>	<b>R2B</b>	
	One SPDT (4 wire)	<b>A3</b>	<b>L3</b>	<b>Z3</b>	<b>R3</b>	
	Two SPDT (4 wire)	<b>A4</b>	<b>L4</b>	<b>Z4</b>	<b>R4</b>	
	One SPDT (3 wire) gold contact Two SPDT (3 wire) gold contact	<b>A71</b> <b>A72</b>	<b>L71</b> <b>L72</b>	<b>Z71</b> <b>Z72</b>	<b>R71</b> <b>R72</b>	
These options all contain inscribed scale with pointer plus hazardous location switches selected to the right. Note that the box is not rated, only the switches.	One SPDT hazardous location (all classes, groups and divisions)				<b>R7</b>	
	One DPDT hazardous location (all classes, groups and divisions)				<b>R17</b>	
	One SPST hazardous location proximity (all classes, groups and divisions)				<b>R30</b>	
	Two SPST hazardous location proximity (all classes, groups and divisions)				<b>R31</b>	
	One SPDT (3 wire) hermetically sealed	<b>A53</b>	<b>L53</b>	<b>Z53</b>		
	Two SPDT (3 wire) hermetically sealed	<b>A54</b>	<b>L54</b>	<b>Z54</b>		
These options all contain a 4-20 mA transmitter and one of the selections to the right.	No switches (Intrinsically safe with barrier)	<b>AX0</b>	<b>LX0</b>	<b>ZX0</b>	<b>RX0</b>	<b>TX0</b>
	One SPDT (3 wire), CE				<b>RX1</b>	<b>TX1</b>
	Two SPDT (3 wire), CE				<b>RX2</b>	<b>TX2</b>
	One SPDT (4 wire)				<b>RX3</b>	<b>TX3</b>
	Two SPDT (4 wire)				<b>RX4</b>	<b>TX4</b>
	One SPDT (3 wire) high temperature				<b>RX61</b>	<b>TX61</b>
These options all include a 4-20 mA transmitter with a digital LCD display plus one of the selections to the right.	No switches					<b>TXL0</b>
	One SPDT (3 wire), CE					<b>TXL1</b>
	One SPDT (4 wire)					<b>TXL3</b>

## ENGINEERING DATA

### Maximum fluid temperature:

PVC housing:	100°F (38°C)
Polysulfone housing:	200°F (95°C)
Tefzel housing:	200°F (95°C)

### Maximum ambient temperature:

130°F (55°C) (UL listed to 105°F (40°C);  
for hazardous locations -13 to +104°F.)

### Maximum operating pressures: (3:1 safety factor)

PVC housing:	100 PSI (6.90 BAR)
Polysulfone housing:	200 PSI (13.79 BAR)
Tefzel housing:	150 PSI (10.3 BAR)

### Readout accuracy, full scale: ±5%

Switch repeatability is 1% of actual flow rate

## FLOW & PRESSURE DROP

Maximum flow ranges to 8 GPM/32 LPM = pressure drop from 1.9 to 2.5 PSID (2.2 PSID average).

Maximum flow ranges to 9 to 12 GPM/45 LPM = pressure drop from 1.9 to 4 PSID (2.95 PSID average).

Maximum flow ranges to 15 GPM/56 LPM = pressure drop from 1.9 to 5 PSID (3.5 PSID average).

Maximum flow ranges to 16 GPM/60 LPM = pressure drop from 1.9 to 5.5 PSID (3.7 PSID average).

Maximum flow ranges to 20 GPM/75 LPM = pressure drop from 1.9 to 6 PSID (4.0 PSID average).

## INSTALLATION

Flow monitors mount in-line and are typically supported by rigid pipe. For additional support when using tubing or flexible hose, order special options **W** (wall) or **F** (foot) mounting brackets.

### MOUNTING BRACKETS (9/32-inch mounting holes)

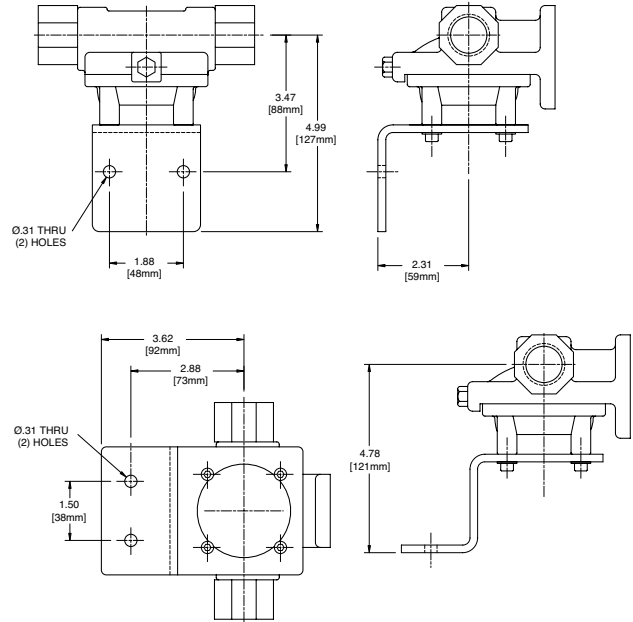

## SPECIAL OPTIONS

**Identification tag:** (option **ST**) customer-supplied information is stamped on a stainless steel tag that is attached to the nameplate.

**High Accuracy:** (option **HA**) Modification of full scale to +/-3%. HA not available with transmitter or R7, R17, R18, R19 switch options. Water viscosities require a flow rate of 3 GPM or greater. Oil viscosities (200 SSU and greater) require flow rates of 1 GPM or greater.

**Multi-pin connector:** Pin connectors (option **PC**) are available for rapid field installation. Meters are provided with the male half of either a micro or a mini pin connector. Check the chart below for the number of pins required for your control box selection and current type. Insert the number of pins in the code PC\_\_ for a mini connector or PC\_\_M for a micro connector. For example, a PC5 would be a 5 pin mini and PC5M would be a 5 pin Micro.

**Tempered-glass window:** (option **TG**) replaces the standard window. A tempered-glass window is employed where airborne solvents or high-ambient temperatures are common.

**Clearance vane:** (option **Z86**) the swing vane is modified to provide extra clearance for liquids that contain particulate. Available for maximum flow range of 5 TO 9 GPM. This reduces the turndown. The minimum flow is 1.5 GPM. Z86 is standard for maximum flows 10 to 20 GPM.

### Number of pins required for various combinations of current type, box type and switch option.

Box	AC switch options	1, 1B, 61, 71		2, 2B, 54, 62, 72		3	53	
	DC switch options	0	1, 1B, 61, 71	3	2, 2B, 54, 62, 72	3	53	
A			3	4	6	5	3	4
R			3	4	6	5	3	4
RX	3							
TX	3	3	3	4			3	4
TXL	3	3	3	4			3	4

\*This box allows micro pin connectors only. Eg. PC3M or PC5M.

## CONTROL BOX SELECTION GUIDE

### “A”, “L” and “Z” Boxes



“A” box is selected for price and simplicity.

It holds switches (general purpose and hermetically sealed) or 4-20mA transmitter.

You get this control box when you order any CONTROL BOX & READOUT starting with an “A” (see "How to Order" page). Examples: A1WR is a one switch, weatherproof box with flow from left to right.

This control box is made of Polysulfone (standard low cost “A”) with options for aluminum (“L”) or 316 stainless steel (“Z”).

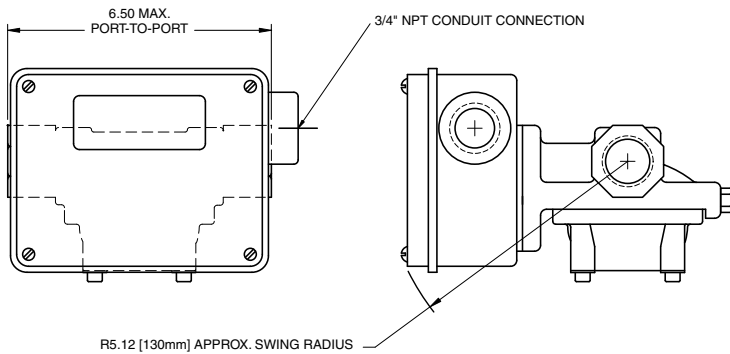

Maximum installation dimensions

### “R” Box



“R” box is selected for greater resolution (more increments on the inscribed scale).

It holds switches (general purpose and hazardous location all classes groups and divisions) and 4-20mA transmitter. Switch (standard service) and transmitter are offered in this control box together when signal redundancy is desired.

You get this control box when you order any CONTROL BOX & READOUT starting with an “R” (see "How to Order" page). Examples: R1WR is a one switch, weatherproof box with flow from left to right.

This control box is made from epoxy coated aluminum.

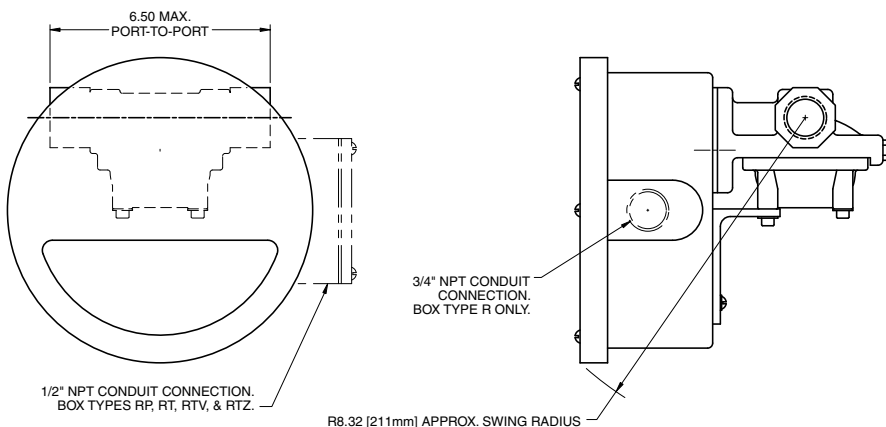

Maximum installation dimensions

## CONTROL BOX SELECTION GUIDE

### “T” Box



“T” box is selected for availability of two isolated junction boxes with terminal strips. This means that no direct wiring to switches or transmitters is required.

Digital LCD display of flow is optional (“TXL”).

It holds switches (general purpose) and 4-20mA transmitter. Switch (standard service) and transmitter are offered in this control box together when signal redundancy is desired. These are wired to separate junction boxes for signal isolation.

You get this control box when you order any CONTROL BOX & READOUT starting with a “T” (see "How to Order" page). Examples: TX1WR is a one switch with 4-20mA transmitter, weatherproof box with flow from left to right.

This control box is made from epoxy coated aluminum.

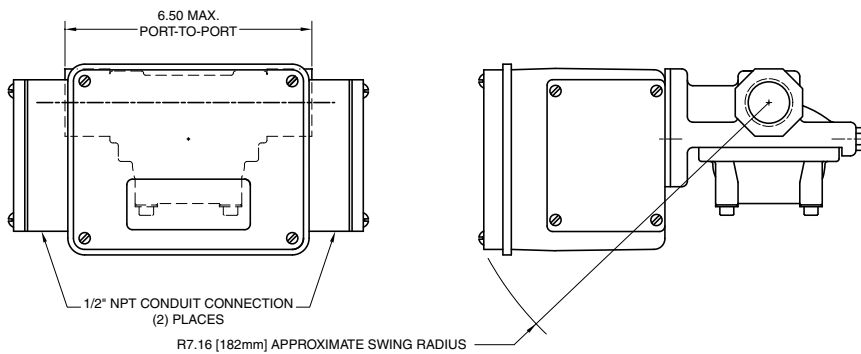

Maximum installation dimensions

OVERALL PORT-TO-PORT DIMENSIONS FOR ALL SX METERS WITH ADAPTER FITTINGS. ALL DRAWINGS ARE SHOWN WITH FEMALE PLASTIC FITTINGS.

FITTING SIZE NPTF	A (INCHES)
1/4, MALE	6.00
1/2, MALE	6.25
3/4 OR 1, MALE	6.50
ALL FEMALE PLASTIC	5.50
ALL FEMALE S.S.	5.88