

Magnetic Rotor Level Indicator

For working pressures up to 800kPa

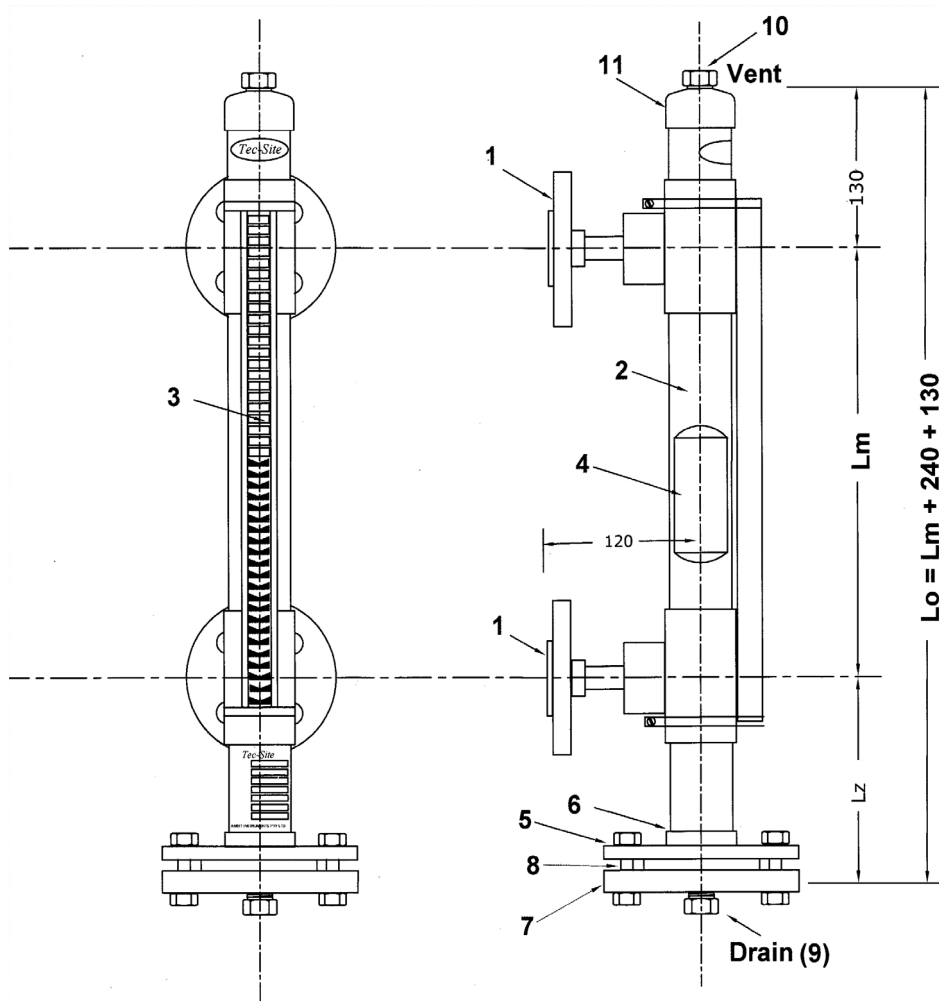

1. Process Connections : Flanged PVC, 1/2" to 2"
 2. Float Chamber : PVC-U
 3. Indication Rail : Polycarbonate/Aluminium, colours red/white
 4. Float : PVC-U
 5. Backing Flange : 316L St St
 6. Float tube Flange : PVC-U
 7. End Flange : PVC-U, 2" ANSI 150#, tapped 1/2"BSPT
 8. Gasket : PTFE Full face
 9. Drain : PVC-U, 1/2"BSPT
 10. Vent : PVC-U, 1/2"BSPT
 11. End Cap : PVC-U, tapped 1/2"BSPT
- Lz Lengths : 240mm

Pressure Rating : *800 kPa, hydro tested (cert included) to 1000 kPa. (*Temp. dependant)
 Temperature rating : 60 Deg C

**Sales of ALL products are subject to our General Conditions of Quotation & Supply.
 Technical specifications are subject to change without prior notice.**



ACN No 50 005 613 641

42 TITAN DRIVE CARRUM DOWNS 3201 VICTORIA AUSTRALIA.

Phone: 03.9776.8888 Fax: 03 9776.8656

Email: contact@ambitinst.com.au

www.ambitinst.com.au



WORLD RECOGNISED
ACCREDITATION

LAB No 3103