

Limit value switches (electromechanical)

Snap-action contact

from AMBIT Instruments Pty Ltd

General

Electromechanical limit value switches in pointer-type measuring instruments are auxiliary current switches which - depending on the direction of movement - open or close electrical circuits at the set limit values by means of a contact arm which is moved by the actual value pointer.

Snap-action contacts essentially comprise:

- an adjustable red set pointer
- a supporting arm which is connected to the red set pointer and carries the contact pin and the adjustable magnet, and
- a contact arm moved by the actual value pointer carrying the second contact pin.

An adjusting lock provided with a separate or fixed key is used for external adjustment of the set pointers of the built-in limit value switches to set the value at which the switching operation is to take place.

Our limit value switches are designed in such a way that the actual value pointer can move past the adjusted set pointer after the contact has been made; once made, however, the contact is maintained which means that even in the event of a power failure, this configuration guarantees stable switching in harmony with the position of the actual value pointer.

In our limit value switches, we use a non wearing jewel bearing consisting of a stainless steel shaft and 2 axially arranged synthetic rubies. This bearing is easy running, electrically insulating, resistant against aggressive media, and guarantees optimum safety even under extreme conditions of application.

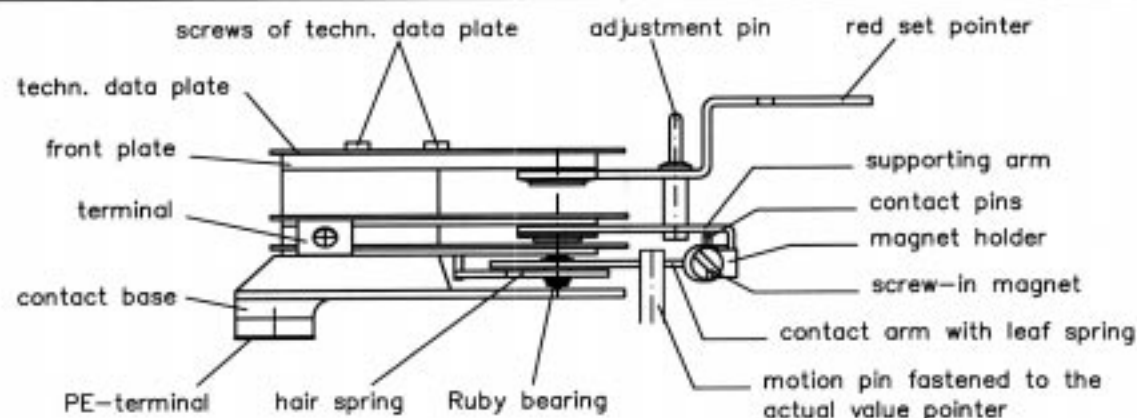

Mode of operation

The snap-action contact is a mechanical contact for switching capacities up to 30 W 50 VA max. Contact making will be delayed and or advanced in relation to the movement of the actual value pointer.

To close the circuit, the contact pin of the movable contact arm is attracted in a jump by the permanent magnet fastened to the supporting arm shortly before the set value has been reached. Due to the retention force of the magnet, snap-action contacts are more resistant against shock and vibration.

The switching safety is increased by the increased contact pressure.

When the circuit is opened, the magnet keeps the contact arm in its place until the restoring force of the measuring element exceeds the magnetic force, and the contact opens in a jump.

This sudden way of switching reduces the formation of a light arc between the contact pins and in this way allows for an increased switching performance.

A technically perfect function will, of course, require an optimum contact adjustment. Kindly refer to our instructions on catalogue page K 14-10.040.