

AMBIT DIAPHRAGM SEALS

CHEMICAL - TWO PIECE SCREWED “CLEAN-OUT” TYPE

Model/Type: ADS-125

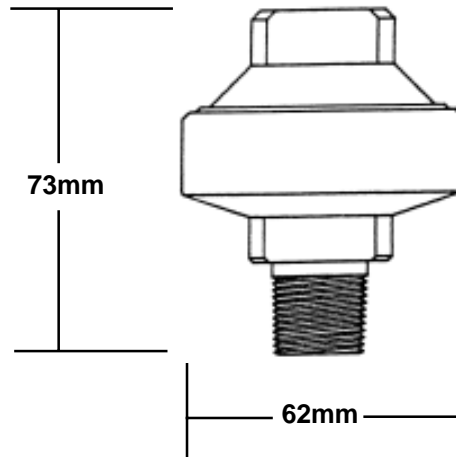

Technical Specifications

- Two piece body, screwed housing, 316 s/steel construction
- Diaphragm: 40mm diameter 316 s/steel welded to top chamber
Note- Splitting the housing does not affect the integrity of the fill.
- Nitrile ‘O’ Ring Seal (standard)
- Nominal Pressure Range -70 to +60,000 kPa
- General purpose, chemical and petroleum applications
- 3/8” BSPP or 1/2” NPT Instrument Connection
- 3/8” BSPT-M or 1/2” NPT-M Process Connection
- All welds integrity tested with helium
- Standard “fill” fluid non-toxic silicon oil, Dow Corning 200 Fluid 100CS
- Options: Other diaphragm and housing materials available on request

AMBIT Instruments Pty Ltd Head Office: 42 Titan Drive Carrum Downs Vic 3201
Phone: 03 9776.8888 Fax: 03 9776.8656 email: contact@ambitinst.com.au
Website: www.ambitinst.com.au
NSW Office: 29/2 O’Connell St. Parramatta NSW 2150 Phone: 02 9891.1222
Fax: 02 9891.1260 email: nswsales@ambitinst.com.au

